



# FORX

## ES16-RS Electric Stacker 1.6t

High Strength Structure Suits High Racking Applications;  
Various Options Such As Foldable Platform, Protection Arm  
& Power Steering  
Side positioned drive system, easy to manage stability

**ENERGY ADVANCE CO., LTD**  
[www.forx.co.th](http://www.forx.co.th)



# FEATURE

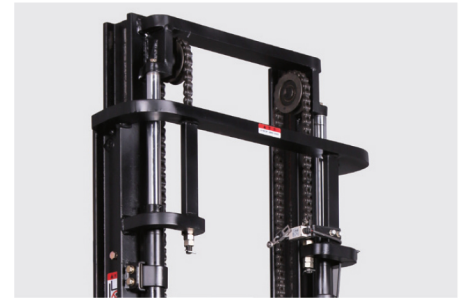

## Performance:

- The innovative AC system offers strong power, accurate control, excellent performance.
- High strength vertical gearbox, longer working life.
- Low-noise but durable hydraulic unit, good quality cylinder as well as hose ensure the high reliability of hydraulic system.
- AMP connector electric wires and cables, greatly reducing electric parts failure rate.
- H shape channel mast improves the strength of the whole truck.
- High strength chassis enhances the reliability and durability of the truck.

## Safety:

- Safe hydraulic system design prevents mast from falling down abruptly when hydraulic pipeline cuts off.
- Full speed will be only available when protection arms are open, low speed mode will be automatic on otherwise.
- Emergency reverse belly button protects the operator from getting hurt.
- Emergency disconnecter will cut off power source to avoid accident when truck goes out of control.
- Multiple lifting limit protection ensures safety.
- Automatic switch to lower speed when the fork reaches its setting height.
- Auto-slow down feature on turning, ensure smooth and safe operation.
- Anti-rolling back brake keeps the truck from skidding down when truck is out of control or travelling on ramp.
- Dual monitoring power steering system

## Maintenance:

- AC traction motor, maintenance free.
- Hour meter and battery indicator remind the operator of battery charging.
- Remove the back cover by only loosening four bolts; Easy access to all key components for inspection, maintenance and replacement.
- Easy access for battery maintenance.
- Vertical motor makes the inspection & service much more convenient.
- Control system allows easy trouble-shooting.
- Mast and chassis are assembled together, easy for maintenance.
- Low voltage cut off setting protects batteries.

## Operation:

- Ergonomic tiller bounded with key switch, BDI and trouble shooting indicator enhances easy and accurate operation.
- Foldable platform reduces vibration which makes operator feel more comfortable when driving.
- When platform is folded, truck can work at low speed in smaller space.
- Ergonomical and durable protection arms guarantee easy operation, with innovative on/off design.
- Electric power steering, smooth & comfortable (EPS).

# Electric Stacker 1.6t

## ES16-RS

Distinguishing mark	1.1	Manufacturer			FORX
	1.2	Model designation			ES16-RS
	1.3	Drive			Electric
	1.4	Operator type			Standing
	1.5	Load capacity	Q	kg	1600
	1.6	Load center distance	c	mm	600
	1.8	Load distance, centre of drive axle to fork	x	mm	693
	1.9	Wheelbase	y	mm	1375
	Service weight	2.1	Service weight		kg
2.2		Axle loading, laden front/rear		kg	960/1880
2.3		Axle loading, unladen front/rear		kg	860/380
Tyres/chassis	3.1	Tyre type			Polyurethane
	3.2.1	Tyre size, front		mm	Φ230x75
	3.3.1	Tyre size, rear		mm	Φ85x70
	3.4	Additional wheels (castor wheels)		mm	Φ130x55
	3.5	Wheels, number front/rear (x=drive wheels)		mm	1x +1/4
	3.6.1	Tread width, front	b10	mm	574
	3.7.1	Tread width, rear	b11	mm	380/495
Dimensions	4.0	Max. Lift Height	H	mm	3000
	4.2	Retracted mast height	h1	mm	2020
	4.3	Free lift	h2	mm	100
	4.4	Lift height	h3	mm	2912
	4.5	Height, mast extended	h4	mm	3465
	4.6	Initial lift	h5	mm	—
	4.9	Height of tiller handle in drive position min./max.	h14	mm	1150/1480
	4.10	Height of wheel arms	h8	mm	—
	4.15	Lowered height	h13	mm	88
	4.19	Overall length	l1	mm	2035
	4.20	Length to face of forks	l2	mm	885
	4.21	Overall width	b1/b2	mm	850
	4.22	Fork dimensions	s/e/l	mm	60x190x1150
	4.24	Fork carriage width	b3	mm	—
	4.25	Distance between fork-arms	b5	mm	570/685
	4.26	Distance between wheel arms/loading surfaces	b4	mm	—
	4.31	Ground clearance, laden, below mast	m1	mm	—
	4.32	Ground clearance, center of wheelbase	m2	mm	28
	4.34.1	Aisle width for pallets 1000×1200 crossways	Ast	mm	2605/2965
4.34.2	Aisle width for pallets 800×1200 crossways	Ast	mm	2575/2935	
4.35	Turning radius	Wa	mm	1730/2090	
Performance data	5.1	Travel speed, laden/unladen		km/h	5.5/6.0
	5.2	Lifting speed, laden/unladen		m/s	0.13/0.16
	5.3	Lowering speed, laden/unladen		m/s	0.30/0.22
	5.8	Max. gradeability, laden/unladen		%	8/16
	5.10	Service brake			Electromagnetic
Electric-engine	6.1	Drive motor rating S2 60 min		kW	1.6
	6.2	Lift motor rating at S3 15%		kW	3.0
	6.4	Battery voltage/nominal capacity		V/Ah	24/210
	6.5	Battery weight		kg	200
Addition data	8.1	Type of drive control			AC
	10.5	Steering design			Electronic
	10.7	Sound pressure level at the driver's ear		dB(A)	74

If there are improvements of technical parameters or configurations, no further notice will be given.  
The diagram shown may contain non-standard configurations.

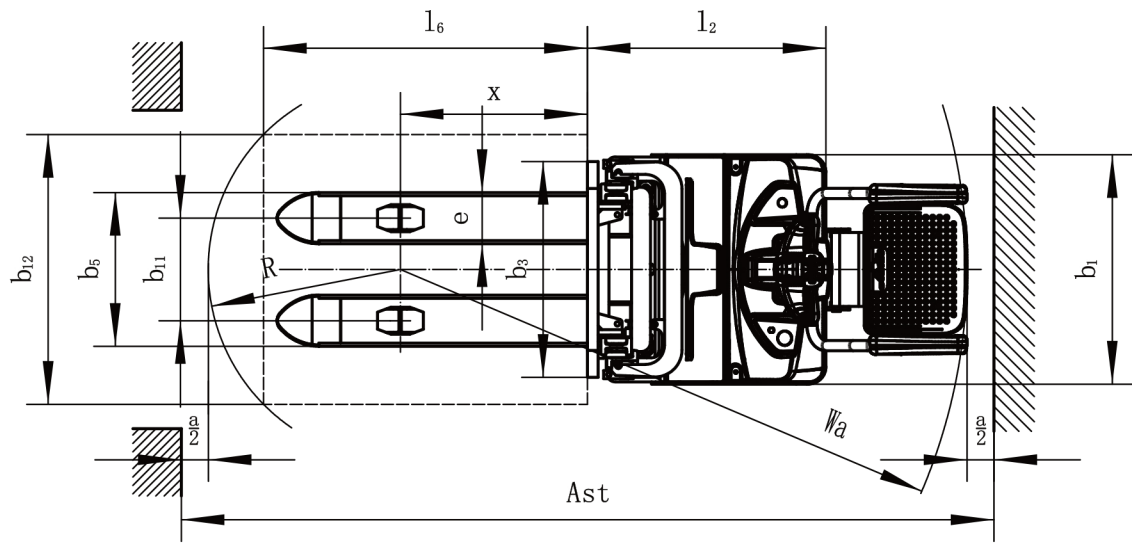
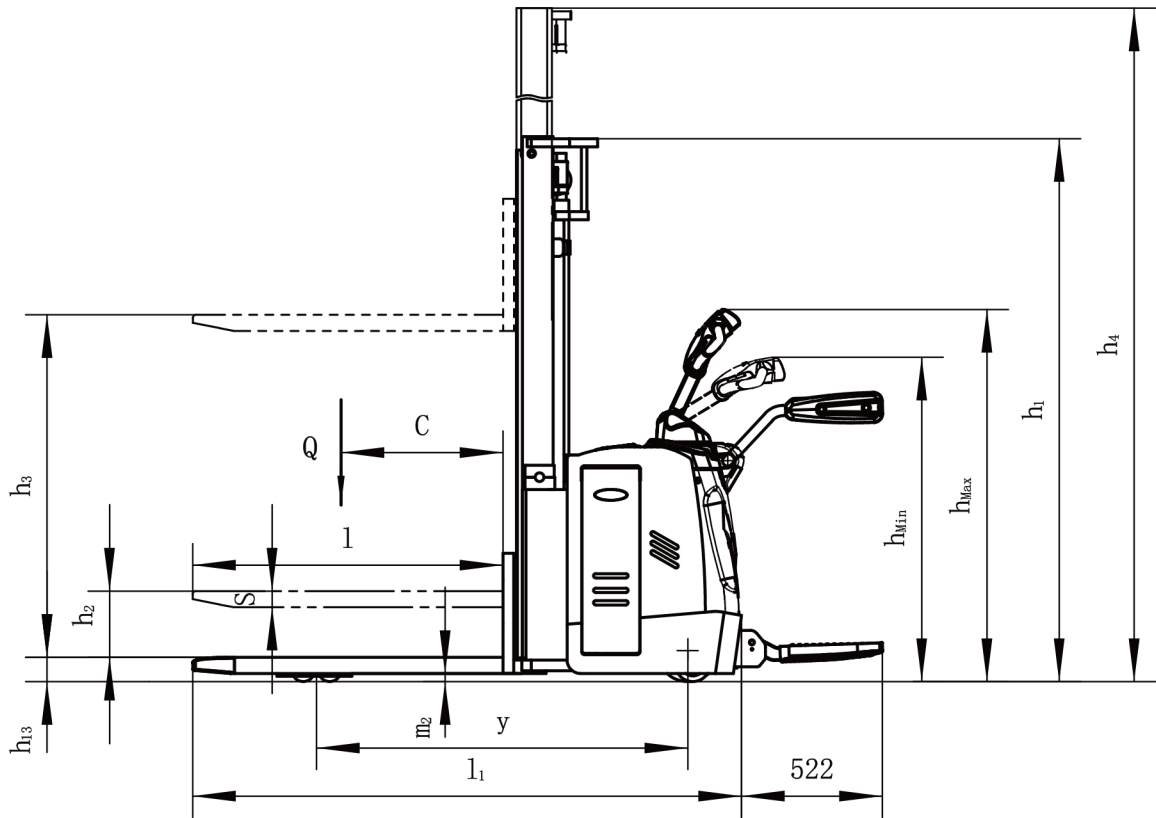

### RATED CAPACITIES GRAPH

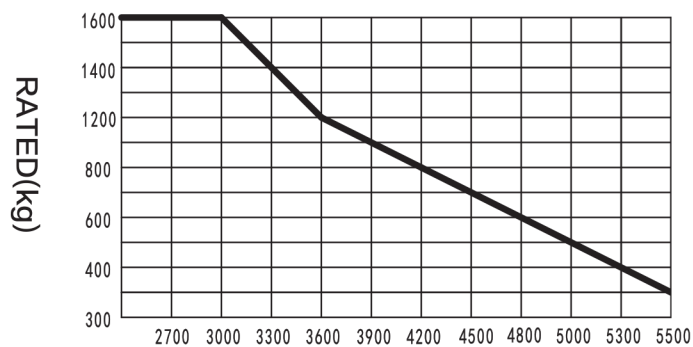

ES16-RS LIFT HEIGHT(mm)

## Mast Option

Mast types	Lift height h3+h13 (mm)	Height, mast lowered h1 (mm)	Free lift h2 (mm)	Height, mast extended h4 (mm)
2-Standard Mast	2700	1870	100	3165
	3000	2020	100	3465
	3300	2170	100	3765
	3600	2320	100	4065
	3900	2470	100	4365
	4170	2600	100	4625
2-Free Mast	2700	1819	1320	3135
	3000	1969	1470	3435
	3300	2119	1620	3735
3-Free Mast	4000	1822	1390	4460
	4500	2022	1590	4960
	4800	2122	1690	5260
	5000	2187	1740	5460
	5300	2287	1840	5760
	5500	2352	1910	5910

## Option

No.	Optional items	ES16-RS		
1.1	Fork length	●1150○1220		
1.2	Fork width	●570○685		
1.3	Fork lowered height	●88		
2.1	Load wheel type	●Double		
2.2	Load wheel material	●PU		
2.3	Drive wheel material	●PU○Trace PU		
2.7	Battery capacity	●210Ah	205AH (Li)	○280Ah
2.8	Charger	●24V-30A External	24V-100A External(for Li-Ion)	○24V-50A External
2.9	Battery indicator	●With time		
3.3	Castor wheels	●		
3.4	Water auto-filling system	○		
3.5	Front lamp	○LED		
3.7	Warning lamp	○		
3.9	Blue lamp	○		
3.11	Rearview mirror	○		
3.12	Hummer	○		
4.1	Battery side pull function	●		
4.2	Cold storage	○		
4.5	Proportional lift system	○		
4.7	Overhead guard	○		
Note: ●Standard ○ Optional - Inconformity				