



# FORX

## F Series - F1

### Electric Pallet Truck 1.5T

- A durable truck for industrial applications
- Platform-based design to maximise competitive advantage in the market
- Cost-saving operations throughout the distribution cycle

# F1 – A durable truck for industrial applications

F Series shares the same highly- integrated tiller design which offers easy management and efficient maintenance for daily usage. It also makes cost-effective distribution process possible by 3 units per box as standard.

F1 inherits the practical features of EPT20-15ET: integrated charger and 24V/65Ah AGM battery for industrial needs and market-proven drive unit for endurance and stability.

F1 is an optimized solution for those who undertake heavy-duties in rugged scenarios.



## Why F Series ?

### ■ Platform-based design to maximise competitive advantage in the market

F series features the platform F, which simplifies the configuration of the truck and allows buyers to choose from 4 different chassis by application. The product design provides value and creates a flexible product strategy by introducing new equipment that meets various market requirements.

### ■ Cost-saving operations throughout the distribution cycle

3 units per box as standard wholesale supply reduces overall spending through the entire distribution process. F1 accommodates **132 units** in a 40' shipping container compared to 64 units of EPT20-15ET, that can reach as high as **50%** of ocean freight charges reduction.

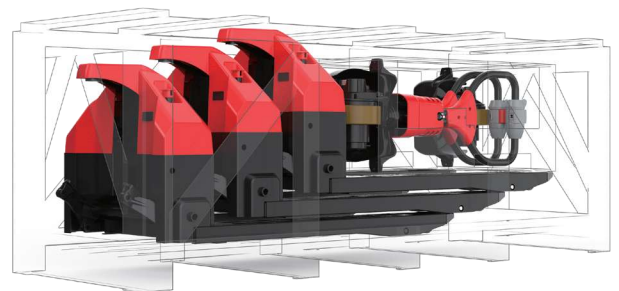

# Electric Pallet Truck 1.5T

## F1

Distinguishing mark	1.1	Manufacturer			FORX
	1.2	Model designation			F1
	1.3	Drive			Electric
	1.4	Operator type			Pedestrian
	1.5	Load capacity	Q	kg	1500
	1.6	Load center distance	c	mm	600
	1.8	Load distance, centre of drive axle to fork	x	mm	883/946
	1.9	Wheelbase	y	mm	1157/1220
	Service weight	2.1	Service weight		kg
2.2		Axle loading, laden front/rear		kg	540/1105
2.3		Axle loading, unladen front/rear		kg	115/30
Tyres/chassis	3.1	Tyre type			Polyurethane
	3.2.1	Tyre size, front		mm	210x70
	3.3.1	Tyre size, rear		mm	Φ80x60( Φ74x88)
	3.4	Additional wheels (castor wheels)		mm	Φ74x30( Optional)
	3.5	Wheels, number front/rear (x=drive wheels)		mm	1x 2/4 ( 1x 2/2)
	3.6.1	Tread width, front	b10	mm	-
	3.7.1	Tread width, rear	b11	mm	410 (535)
Dimensions	4.4	Lift height	h3	mm	105
	4.9	Height of tiller handle in drive position min./max.	h14	mm	750/1170
	4.15	Lowered height	h13	mm	82
	4.19	Overall length	l1	mm	1604
	4.20	Length to face of forks	l2	mm	450
	4.21	Overall width	b1/b2	mm	695/620
	4.22	Fork dimensions	s/e/l	mm	55/150/1150
	4.25	Distance between fork-arms	b5	mm	685/560
	4.32	Ground clearance, center of wheelbase	m2	mm	25
	4.34.1	Aisle width for pallets 1000×1200 crossways	Ast	mm	2187
	4.34.2	Aisle width for pallets 800×1200 crossways	Ast	mm	2244
4.35	Turning radius	Wa	mm	1426	
Performance data	5.1	Travel speed, laden/unladen		km/h	4/4.5
	5.2	Lifting speed, laden/unladen		m/s	0.02/0.026
	5.3	Lowering speed, laden/unladen		m/s	0.069/0.055
	5.8	Max. gradeability, laden/unladen		%	5/16
	5.10	Service brake			Electromagnetic
Electric-engine	6.1	Drive motor rating S2 60 min		kW	0.75
	6.2	Lift motor rating at S3 15%		kW	0.5
	6.4	Battery voltage/nominal capacity		V/Ah	12*2/65Ah
	6.5	Battery weight		kg	15*2
Addition data	8.1	Type of drive control			DC
	10.5	Steering design			Mechanical
	10.7	Sound pressure level at the driver's ear		dB(A)	<74

If there are improvements of technical parameters or configurations, no further notice will be given.  
The diagram shown may contain non-standard configurations.

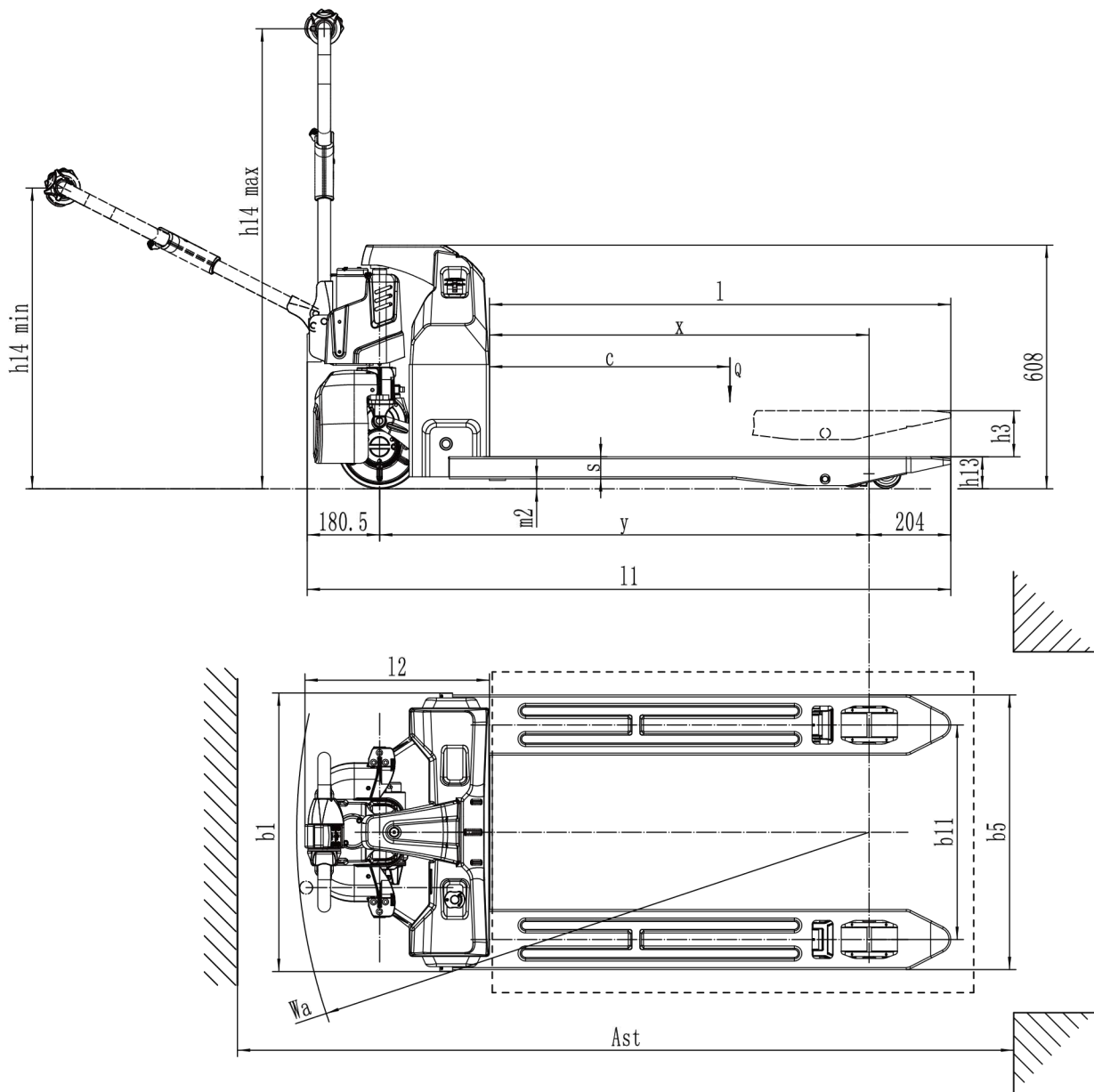

## Option:

No.	Optional items	F1
1.2	Fork width	●1150*560 ○560*900/1000/1220/1350/1500○1150*685○685**900/1000/1220/1350/1500
1.3	Fork lowered height	●80
1.6	Drive cover off the ground	●45mm○65mm(Non-CE)
2.1	Load wheel type	●Double○Single
2.2	Load wheel material	●Polyurethane
2.3	Drive wheel material	●Polyurethane
2.7	Battery capacity	●24V 65Ah
2.8	Charger	●24V-10A Internal
2.9	Battery indicator	●Without time
3.12	Buzzer	●Yes and not customized
2.16	Handle head type	●Hands handle head
3.3	Castor wheels	●No○Yes and not customized
3.16	Vertical handler working	●Yes and not customized
4.8	Drive assembly	●Yes and not customized

Note: ●Standard ○ Optional - Inconformity