



FORX

RSC152/202

1.5/2.0 ton Electric Counterbalance Stacker

- Universal for various size of pallets
- Proportional lifting system offering utmost precision
- High ground clearance for comfortable travel on uneven surfaces
- Compact size for great maneuverability

ENERGY ADVANCE CO., LTD
www.forx.co.th

FEATURE

■ Universal for various size of pallets

The RSC series provides all the versatility for various kinds of pallets and loads and operators are allowed to transport loads of special sizes. This can help accelerate goods circulation and improves productivity. Besides, the RSC series offers sensitive mast tilting which delivers more convenience to pallet stacking, compared to regular stackers.

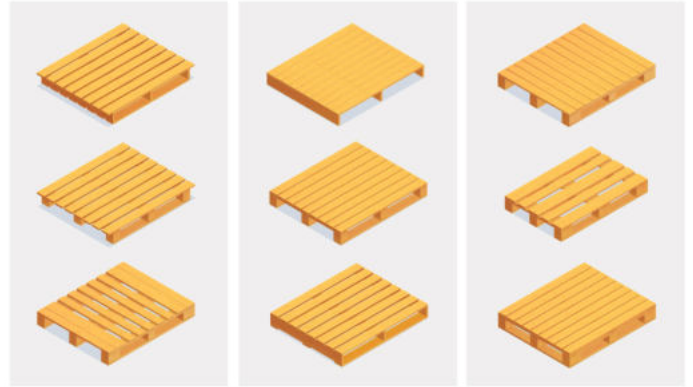

■ Proportional lifting system offering utmost precision

The RSC series comes with the proportional lifting system as standard and enables the operator to stack and retrieve pallets more precisely and gently in multi-level racking.

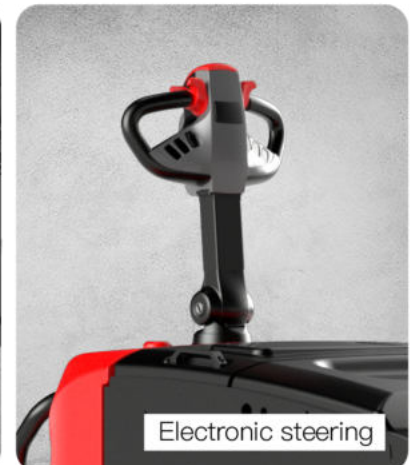

■ High ground clearance for comfortable travel on uneven surfaces

The RSC series offers a high ground clearance 116mm, which makes it high available on uneven surfaces.



■ Compact size for great maneuverability

The RSC series features a compact size, with the turning radius 1707/1915mm, and it can navigate the narrow aisles easily in confined warehouse areas.



1.5/2.0 ton Electric Counterbalance Stacker

RSC152/202

Distinguishing mark	1.1	Manufacturer			FORX	FORX
	1.2	Model designation			RSC152	RSC202
	1.3	Drive			Electric	Electric
	1.4	Operator type			Pedestrian	Pedestrian
	1.5	Load capacity	Q	kg	1500	2000
	1.6	Load center distance	c	mm	500	500
	1.8	Load distance, centre of drive axle to fork	x	mm	215	215
	1.9	Wheelbase	y	mm	1125	1487
	Service weight	2.1	Service weight		kg	2160
2.2		Axle loading, laden front/rear		kg	440/3220	460/3520
2.3		Axle loading, unladen front/rear		kg	1300/860	1460/1020
Tyres/chassis	3.1	Tyre type			Polyurethane	Polyurethane
	3.2	Tyre size, front			230×90	260×105
	3.3	Tyre size, rear			254×102	254×102
	3.5	Wheels, number front/rear (x=drive wheels)		mm	1x,/2	1x,/2
	3.6	Tread width, front	b ₁₀	mm	—	—
	3.7	Tread width, rear	b ₁₁	mm	787	787
Dimensions	4.1	Tilt of mast/fork carriage forward/backward	α/β	°	1.5/7	1.5/7
	4.2	Retracted mast height	h ₁	mm	2018	2118
	4.3	Free lift	h ₂	mm	150	150
	4.4	Lift height	h ₃	mm	3000	3000
	4.5	Height, mast extended	h ₄	mm	3915	3915
	4.7	Height of overhead guard (cabin)	h ₆	mm	—	—
	4.8	Seat height/standing height	h ₇	mm	148	148
	4.12	Tow coupling height	h ₁₀	mm	—	—
	4.19	Overall length	l ₁	mm	2968	3178
	4.20	Length to face of forks	l ₂	mm	1898	2018
	4.21	Overall width	b ₁ /b ₂	mm	900	900
	4.22	Fork dimensions	s×e×l	mm	40×100×1070	40×122×1070
	4.23	A,B Fork carriage class/type A, B			2A	2A
	4.24	Fork carriage width	b ₃	mm	800	800
	4.31	Ground clearance, laden, below mast	m ₁	mm	80	80
	4.32	Ground clearance, center of wheelbase	m ₂	mm	116	116
	4.34.1	Aisle width for pallets 1000×1200 crossways	Ast	mm	3270	3478
	4.34.2	Aisle width for pallets 800×1200 lengthways	Ast	mm	3380	3588
	4.35	Turning radius	Wa	mm	1707	1915
Performance data	5.1	Travel speed, laden/unladen		km/h	5.5/6	5.5/6
	5.2	Lifting speed, laden/unladen		m/s	0.13/0.2	0.10/0.16
	5.3	Lowering speed, laden/unladen		m/s	0.16/0.15	0.19/0.16
	5.5	Drawbar pull, laden/unladen		N	—	—
	5.6	Max. drawbar pull, laden/unladen		N	—	—
	5.8	Max. gradeability, laden/unladen		%	5/8	5/8
	5.10	Service brake			Electromagnetic	Electromagnetic
5.11	Parking brake			Electromagnetic	Electromagnetic	
Electric-engine	6.1	Drive motor rating S2 60 min		kW	1.6	3.3
	6.2	Lift motor rating at S3 15%		kW	3.0	3.0
	6.4	Battery voltage/nominal capacity		V/Ah	24/210	24/210
	6.5	Battery weight		kg	190	190
	8.1	Type of drive control			AC	AC
Addition data	10.5	Steering design			Electronic	Electronic
	10.7	Sound pressure level at the driver's ear		dB(A)	74	74
	15.1	Charger output current		A	30	30

If there are improvements of technical parameters or configurations, no further notice will be given.
The diagram shown may contain non-standard configurations.

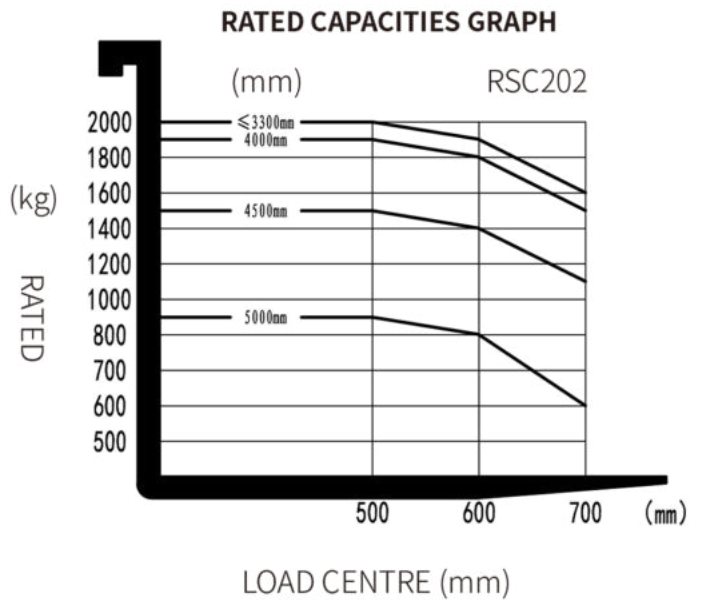
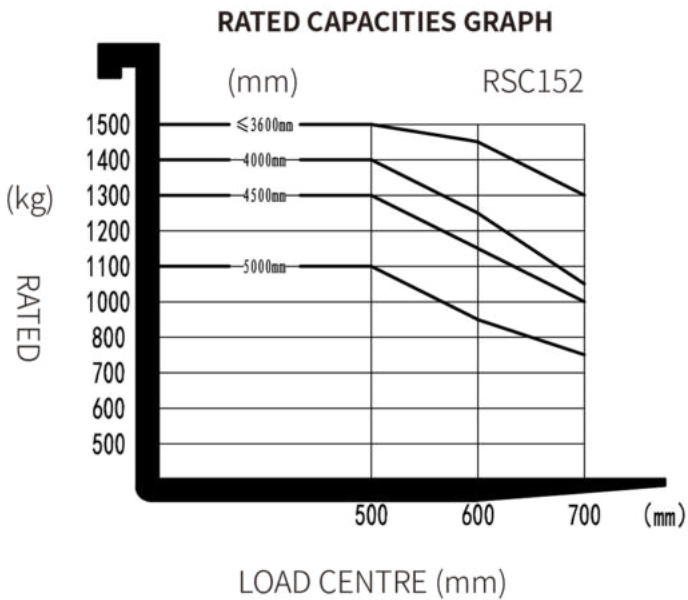
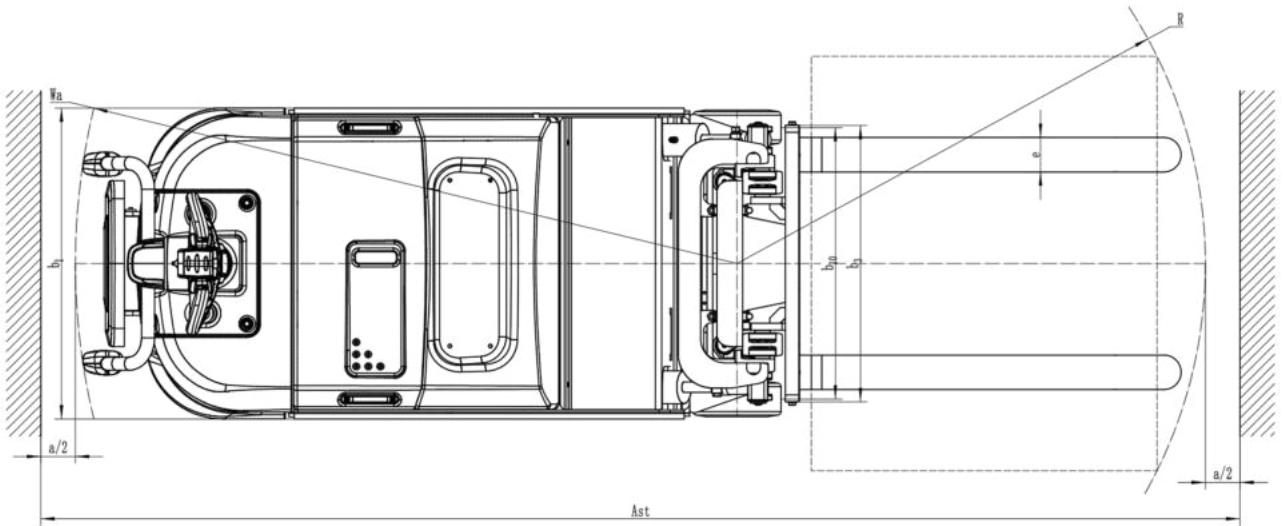
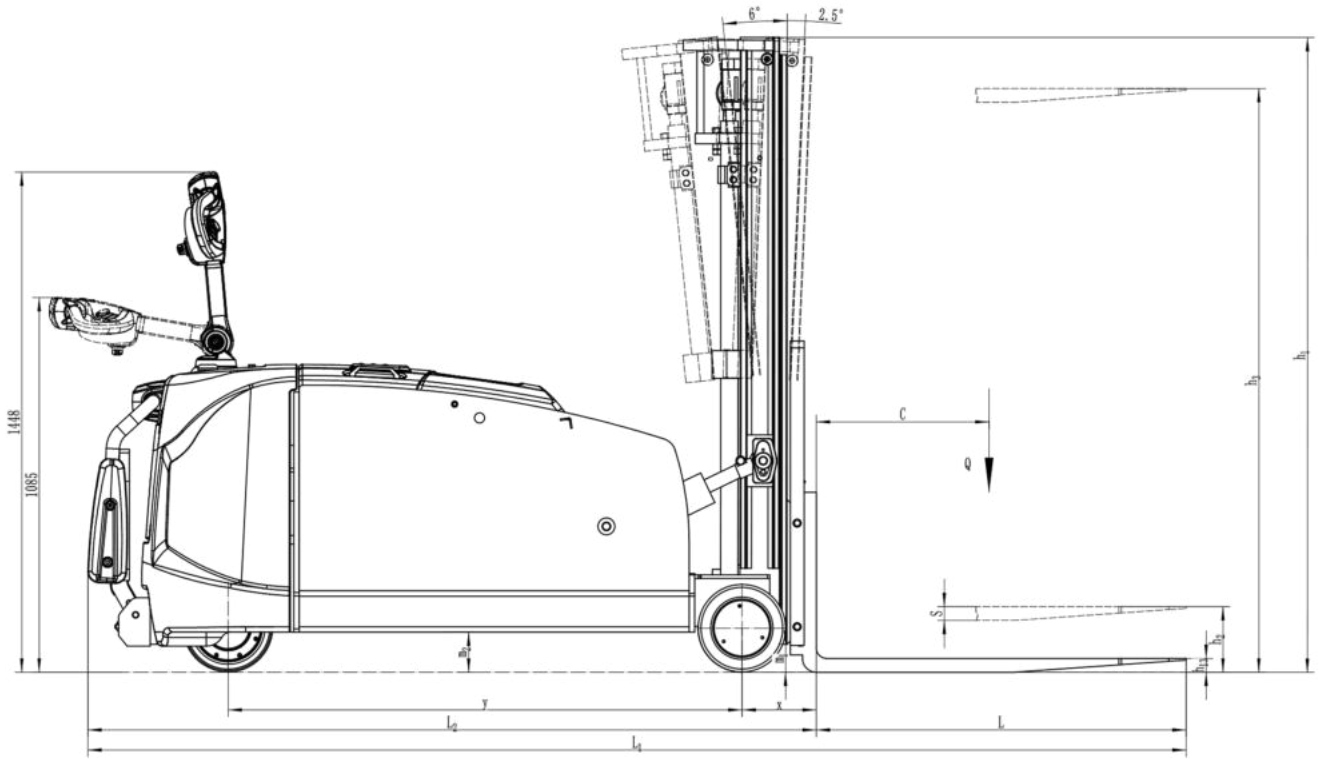

Mast option:

Mast types	Lift height (h3)	Height, Mast			Height, Free lift(h2)	
		Height, mast lowered(h1)	Height, mast extended(h4)		No shelving	With shelving
	No shelving		With shelving	mm		
2-Standard Mast	2600	1838	—	3555	—	150
	3000	2018	—	3915	—	150
	3200	2118	—	4115	—	150
	3600	2303	—	4505	—	150
	3900	2453	—	4805	—	150
3-Free Mast	4000	1822	—	4915	—	904
	4500	2022	—	5415	—	1104
	4800	2122	—	5715	—	1204
	5000	2187	—	5915	—	1274

Option:

No.	Optional items	RSC152	RSC202
1.1	Fork dimension	<ul style="list-style-type: none"> ●900*600、2A、100*40*1070 ○900*600、2A、100*40*920 ○900*600、2A、100*40*1150 ○900*600、2A、100*40*1220 ○900*600、2A、100*40*1370 ○900*600、2A、100*40*1520 	<ul style="list-style-type: none"> ●1250*500、2A、122*40*1070 ○1250*500、2A、122*40*1150 ○1250*500、2A、122*40*1220 ○1250*500、2A、122*40*1370 ○1250*500、2A、122*40*1500
1.3	Fork lowered height	●60	●60
1.4	Fork carriage width	●780○915○1067○1220	●780○915○1067○1220
1.5	backrest height	●915○1220	●915○1220
2.2	Load wheel material	●Polyurethane	●Polyurethane
2.3	Drive wheel material	●Polyurethane	●Polyurethane
2.7	Battery capacity	<ul style="list-style-type: none"> ●210Ah (Lead acid) ○280Ah (Lead acid) ○345Ah (Lead acid) ○205Ah (Li-ion) 	<ul style="list-style-type: none"> ●210Ah (Lead acid) ○280Ah (Lead acid) ○345Ah (Lead acid) ○205Ah (Li-ion)
2.8	Charger	<ul style="list-style-type: none"> ●24V-30A external (Lead acid) ○24V-50A external (Lead acid) ○24V-100A external (Li-ion) 	<ul style="list-style-type: none"> ●24V-30A external (Lead acid) ○24V-50A external (Lead acid) ○24V-100A external (Li-ion)
2.9	Battery indicator	●With time	●With time
2.11	Attachments	●No○External side shifter	●No○External side shifter
3.4	Water auto-filling system	●No○Yes and not customized	●No○Yes and not customized
3.23	Telematics	●No○Yes and not customized	●No○Yes and not customized
3.26	Foldable platform + arm guard	●Yes and not customized○No	●Yes and not customized○No
4.1	Battery side pull function	●No	●No
4.5	Proportional lift system	●Yes and not customized	●Yes and not customized
4.6	Forks tilt forward and backward	●Yes and not customized	●Yes and not customized

Note: ●Standard ○ Optional - Inconformity