

# EFX2-251

## Li-ion Counterbalance Forklift Truck 2500kg



- The most entry-level and budget-friendly alternative to IC trucks and second-hand trucks
- Maintenance free battery and single phase onboard charger with plug for maximum ease of use
- Proportional lifting system for precise operation
- Lithium technology battery and PMSM technology for better energy efficiency and extended runtime
- Waterproof design, high ground clearance and big tyres for both indoor and outdoor applications

Manufacturer			FORX
Model designation			EFX2-251
Drive			Electric
Load capacity	Q	kg	2500
Load center distance	c	mm	500
Service weight		kg	4116
Retracted mast height	h1	mm	2090
Lift height	h3	mm	3000
Height, mast extended	h4	mm	4025
Length to face of forks	l2	mm	2528
Overall width	b1/b2	mm	1154
Fork dimensions	s/e/l	mm	40×122×1070
Turning radius	Wa	mm	2258
Travel speed, laden/unladen		km/h	11/12
Lifting speed, laden/unladen		m/s	0.29/0.36
Lowering speed, laden/unladen		m/s	0.4/0.43
Max. gradeability, laden/unladen		%	15/15
Drive motor rating S2 60 min		kW	8
Battery voltage/nominal capacity		V/Ah	80V/100AH

## FEATURE

### ■ PMSM Technology on traction and lifting motor

Stable power output

10% runtime extended

10-15% energy saving



### ■ 80V/100Ah Li-ion battery with 30A onboard charger

- Easy opportunity charging thanks to the onboard charger with plug
- Zero maintenance and no gas emission allow to recharge everywhere
- Covering the majority of the applications: from light to medium duty and occasional heavy duties



### ■ Easy operation experience

- Proportional lifting system for gentle and precise stacking
- Adjustable steering wheel, comfortable legroom and suspended seat
- Easy access to main components



### ■ Both indoor and outdoor applications available

- Waterproof design
- Big tyres and high ground clearance



## Key highlights

### Perfect for online sales and rental

The EFX2-251 is designed around simplicity and cost-effectiveness, perfect for online channels, with zero maintenance and low initial costs needed.



### Ideal alternative to IC trucks and second-hand trucks

The EFX2-251 is positioned as the most entry-level and budget-friendly Li-ion forklift. It can meet both indoor and outdoor demands thanks to its waterproof design and high ground clearance. To deal with strict environmental regulations, the lithium core produces zero carbon emission and complies with sustainability.



# Li-ion Counterbalance Forklift Truck 2500kg

## EFX2-251

Distinguishing mark	1.1	Manufacturer			FORX
	1.2	Model designation			EFX2-251
	1.3	Drive			Electric
	1.4	Operator type			Seated
	1.5	Load capacity	Q	kg	2500
	1.6	Load center distance	c	mm	500
Service weight	1.8	Load distance, centre of drive axle to fork	x	mm	495
	1.9	Wheelbase	y	mm	1650
	2.1	Service weight		kg	4116
	2.2	Axle loading, laden front/rear		kg	5813/803
	2.3	Axle loading, unladen front/rear		kg	1805/2311
	Tyres/chassis	3.1	Tyre type		
3.2		Tyre size, front			7.00-12-16PR
3.3		Tyre size, rear			18X7-8-14PR
3.5		Wheels, number front/rear (x=drive wheels)		mm	2x/ 2
3.6		Tread width, front	b <sub>10</sub>	mm	975
3.7		Tread width, rear	b <sub>11</sub>	mm	955
Dimensions	4.1	Tilt of mast/fork carriage forward/backward	$\alpha/\beta$	°	6/ 10
	4.2	Retracted mast height	h <sub>1</sub>	mm	2090
	4.3	Free lift	h <sub>2</sub>	mm	135
	4.4	Lift height	h <sub>3</sub>	mm	3000
	4.5	Height, mast extended	h <sub>4</sub>	mm	4025
	4.7	Height of overhead guard (cabin)	h <sub>6</sub>	mm	2170
	4.8	Seat height/standing height	h <sub>7</sub>	mm	1110
	4.12	Tow coupling height	h <sub>10</sub>	mm	295
	4.19	Overall length	l <sub>1</sub>	mm	3598
	4.20	Length to face of forks	l <sub>2</sub>	mm	2528
	4.21	Overall width	b <sub>1</sub> /b <sub>2</sub>	mm	1154
	4.22	Fork dimensions	s×e×l	mm	40×122×1070
	4.23	A,B Fork carriage class/type A, B			2A
	4.24	Fork carriage width	b <sub>3</sub>	mm	1040
	4.31	Ground clearance, laden, below mast	m <sub>1</sub>	mm	120
	4.32	Ground clearance, center of wheelbase	m <sub>2</sub>	mm	150
	4.34.1	Aisle width for pallets 1000×1200 crossways	Ast	mm	3953
4.34.2	Aisle width for pallets 800×1200 lengthways	Ast	mm	4153	
4.35	Turning radius	Wa	mm	2258	
Performance data	5.1	Travel speed, laden/unladen		km/h	11/12
	5.2	Lifting speed, laden/unladen		m/s	0.29/0.36
	5.3	Lowering speed, laden/unladen		m/s	0.4/0.43
	5.5	Drawbar pull, laden/unladen		N	—
	5.6	Max. drawbar pull, laden/unladen		N	—
	5.8	Max. gradeability, laden/unladen		%	15/15
Electric-engine	5.10	Service brake			Hydraulic
	5.11	Parking brake			Mechanical
	6.1	Drive motor rating S2 60 min		kW	8
	6.2	Lift motor rating at S3 15%		kW	16
	6.4	Battery voltage/nominal capacity		V/Ah	80V100AH
	6.5	Battery weight		kg	—
	6.6	Energy consumption according to DIN EN 16796		kWh/h	—
	6.7	Turnover output according to VDI 2198		t/h	—
6.8	Turnover efficiency according to VDI 2198		t/kWh	—	
Drive/lift mechanism	8.1	Type of drive control			PSMS
Addition data	10.1	Operating pressure for attachments		bar	
	10.2	Oil volume for attachments		l/min	
	10.5	Steering design			Hydraulic
	10.7	Sound pressure level at the driver's ear		dB(A)	< 74
	15.1	Charger output current		A	

If there are improvements of technical parameters or configurations, no further notice will be given.  
The diagram shown may contain non-standard configurations.

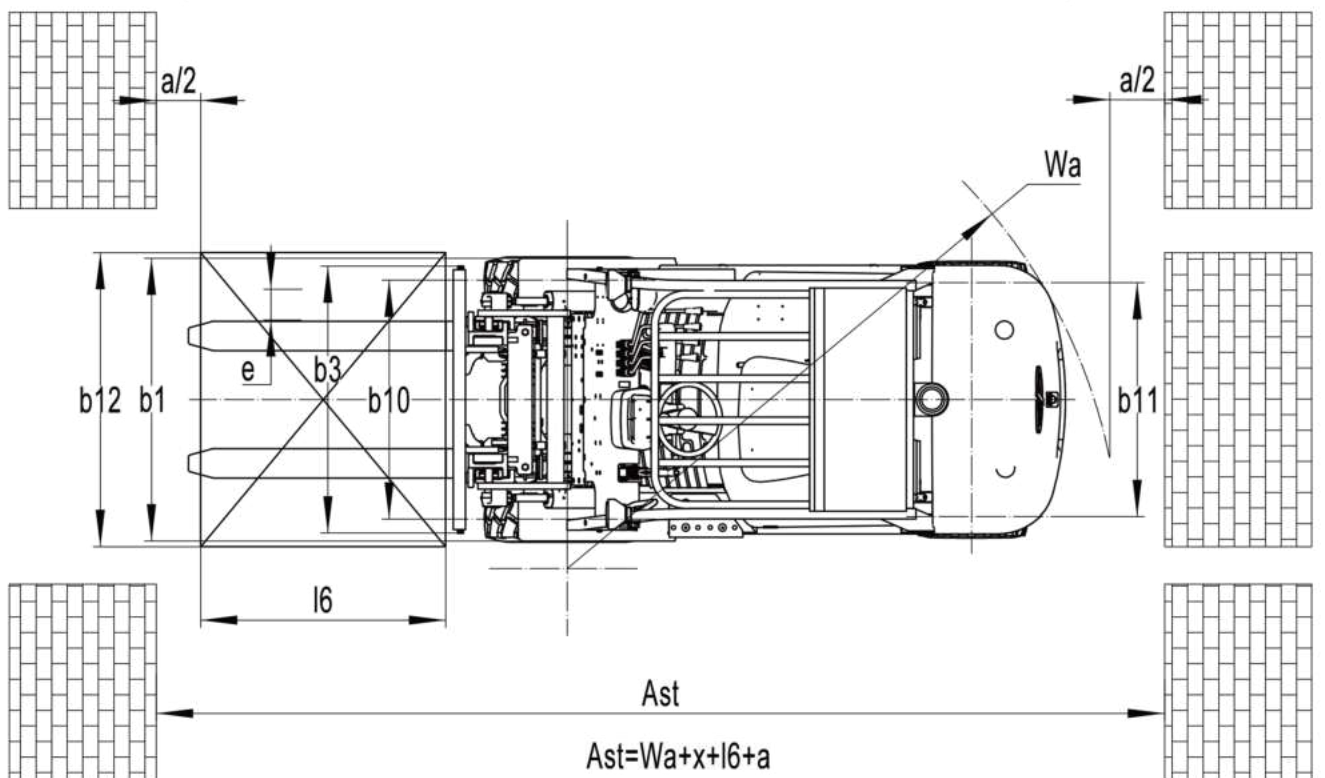
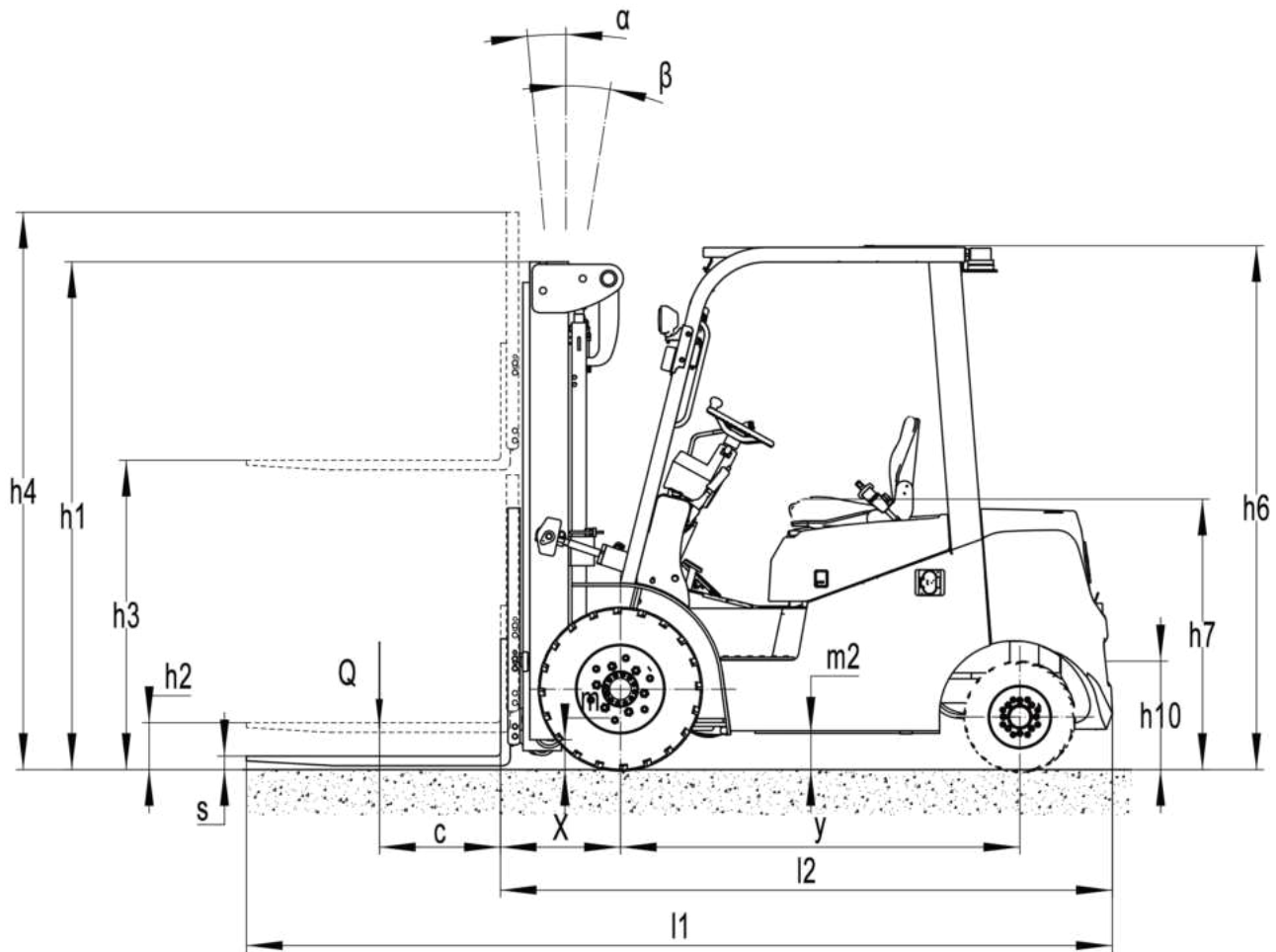

### RATED CAPACITIES AND LOAD CENTERES GRAPH

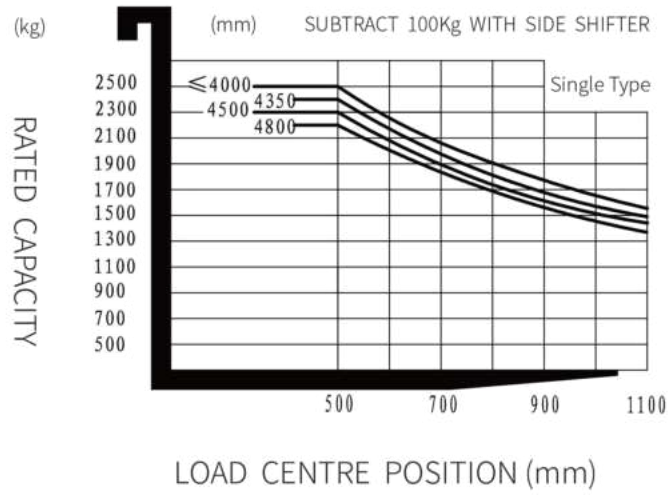

## Mast Option

Mast types	Lift height (h3)	Height, Mast			Height, Free lift(h2)	
		Height, mast lowered(h1)	Height, mast extended(h4)		No shelving	With shelving
	No shelving		With shelving	mm		
2-Standard Mast	3000	2090	3565	4025	120	120
	3300	2240	3865	4325	120	120
3-Free Mast	4500	2115	5065	5525	1550	1090
	4800	2220	5365	5825	1655	1195



# Option

Optional items	EFX2-251
Fork dimension	○122*40*920●122*40*1070○122*40*1150○122*40*1220 ○122*40*1370○122*40*1500○122*40*1600○122*40*1700 ○122*40*1820○122*40*1900○122*40*2000○122*40*2200
Fork carriage width	●1040mm
backrest height	●1025mm
Front wheel material	●Pneumatic○Normal solid○Traceless solid
Rear wheel material	●Pneumatic○Normal solid○Traceless solid
Battery capacity	●80V100AH○80V150AH○80V230AH○80V280AH
Charger	○80V65A (External) ●80V35A(Interior) ○80V60A(Interior) ○80V100A (External, only for 80V230Ah battery)
Battery indicator	●With hourmeter
Seat type	●ordinary○Suspension + safety belt logic switch ○comfortable + safety belt logic switch
Attachments	●No○Built-in sidershifter○External shifter
Traction pin	●Yes and not customized
Electrostatic chain	●Yes and not customized
Front lamp	●LED
Rear lamp	●No○LED
Warning lamp	●Yes and not customized
Steering lamp	●LED
Blue lamp	●None○The first one+ the last one ○The latter one○The first two + the last one
Area warning lamp	●None○Red, one on each side ○One on each side + one on the back
Rearview mirror	●A rearview mirror○Double rearview mirror
Hummer	●Yes and not customized
OPS system	● Yes and not customized○No
USB interface	●Yes and not customized
Remote monitoring	●Yes and not customized○No
Fan heater	●No○Yes and not customized
Speed reduction for elevated mast- Australian standard	●No○Yes and customized
Cabin	●None○Semi-enclosed cockpit ○Fully enclosed cockpit with electric fan, heater, front wipers, rear wipers
Proportional lift system	●Yes and not customized
Overhead guard	●Standard overhead guard○Yes and customizable
Note:	●Standard ○ Optional - Inconformity